

SIMON

design Studio 28 - 2024

cattelan
italia



ISTRUZIONI DI MONTAGGIO - ASSEMBLING INSTRUCTIONS - MONTAGEANLEITUNG
INSTRUCTIONS DE MONTAGE - INSTRUCCIONES DE MONTAJE
ИНСТРУКЦИИ ПО МОНТАЖУ - 安装指导 - تعليمات التجميع

IT Cattelan Italia spa si riserva di apportare, senza preavviso, modifiche nei materiali, nei rivestimenti, nelle finiture e nei disegni dei prodotti. Le textures ed i colori dei materiali e delle finiture hanno valore indicativo in quanto soggetti alle tolleranze dei processi di stampa.

Riporre per eventuali consultazioni future.

EN Cattelan Italia spa reserves the right to change, without previous notice, materials, covers, finishes and drawings of the products. The textures and colours of materials and finishes are indicative as they are depending on the tolerances of the printing process.

File for future consultation.

DE Cattelan Italia spa behält sich vor, ohne Vorankündigung, Veränderungen an den Materialien, Bezügen, Finish und Zeichnungen Produkte vorzunehmen. Die Texturen und Farben der Materialien und Finish haben einen hinweisenden Wert, da sie von den Toleranzen im Druckprozess abhängig sind.

Bitte aufbewahren für eventuelle spätere Nachfragen.

FR Cattelan Italia spa se réserve le droit d'apporter, sans préavis, des modification au niveau des matériaux, des revêtements, des finitions et du design des produits. Les textures et les couleurs des matériaux et des finitions sont une valeurs indicative parce-que ils changent selon la tolérance aux procédés d'imprimerie.

A conserver pour les futurs besoins de reference.

ES Cattelan Italia spa se reserva el derecho de aportar modificaciones de dibujo, materiales, acabados y tapicerías, sin que esté obligada a dar aviso antipado. Las textures y los colores de los materiales y de los acabados tienen solo un valor indicativo porque estan sujetos a la tolerancia en los procesos de imprenta.

Guardar para consultas posteriores.

RU Cattelan Italia spa оставляет за собой право делать изменения, без предупреждения, в материалах, обивках, отделках и в чертежах продуктов, которые представлены в данном каталоге. Текстуры и цвета материалов и отделок в каталоге не передают реальные цвета предметов, из-за особенности процессов печати и цветопередачи.

Сохранить для возможной будущей консультации.

CN Cattelan Italia

公司保留变更图册中材料、包覆材质、饰面、图像的权利，无须事先通知。因印刷等工艺存在偏差，材料和饰面等的纹理和颜色仅供参考。
重要事项：存档以备日后咨询

AR تحتفظ شركة Cattelan Italia SPA بالحق في تغيير المواد والأغطية والتشطيبات والرسومات الخاصة بالمنتجات دون إشعار مسبق.

تعتبر قوام وألوان المواد والتشطيبات إرشادية لأنها تعتمد على تفاوتات عملية الطباعة.

هام: ملف للتشاور في المستقبل.



HARDWARE

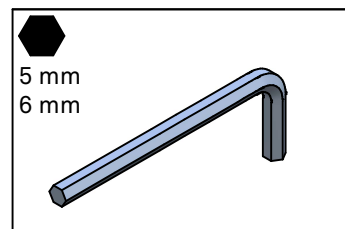
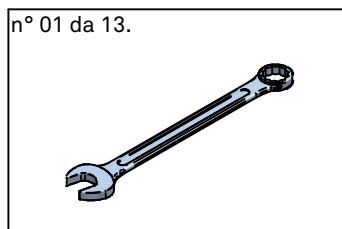
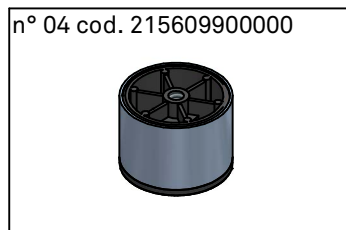
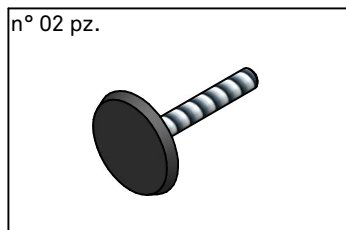
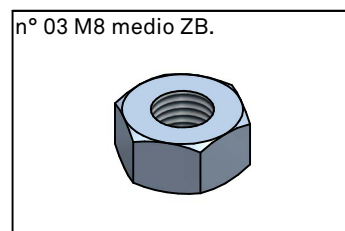
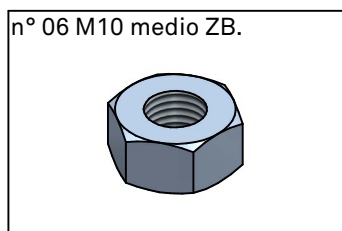
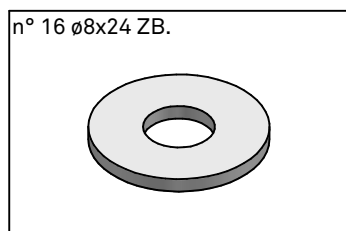
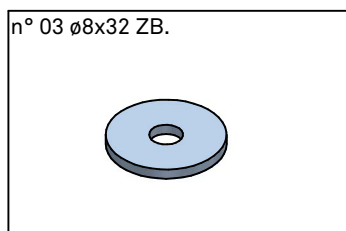
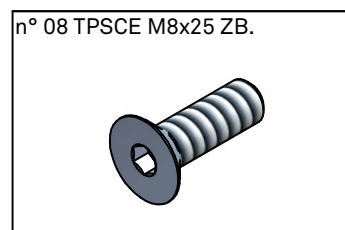
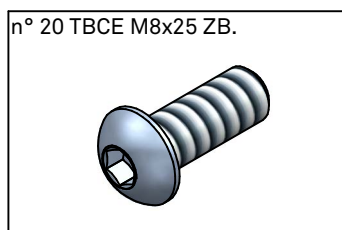
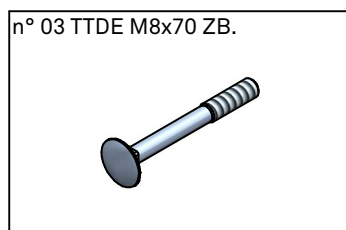
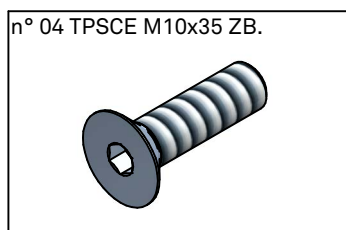

n° 04 TPSCE M10x35 ZB.



n° 04 M10 medio ZB.

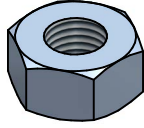

n° 04 cod. 215609900000

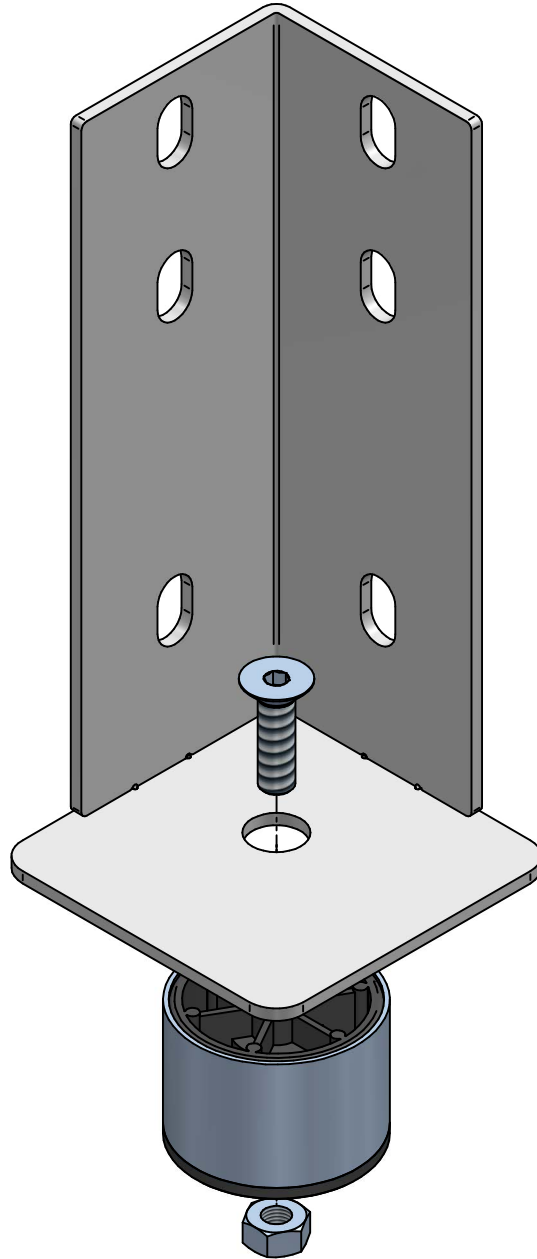

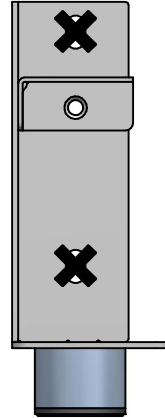
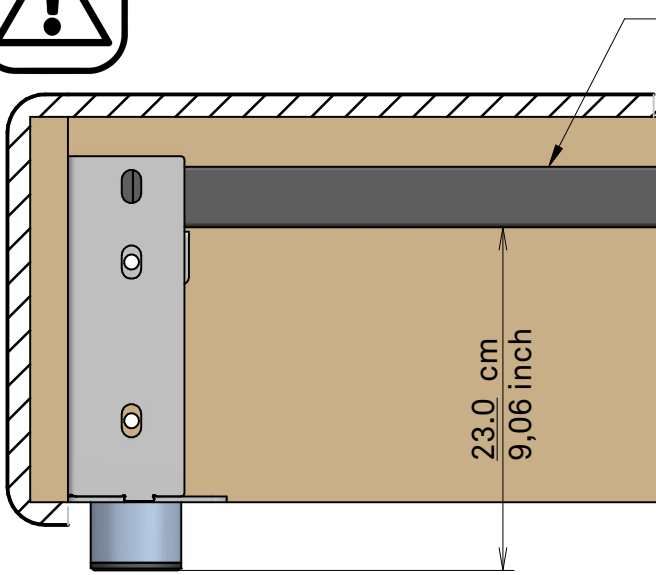

06

2b

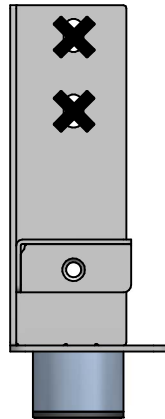
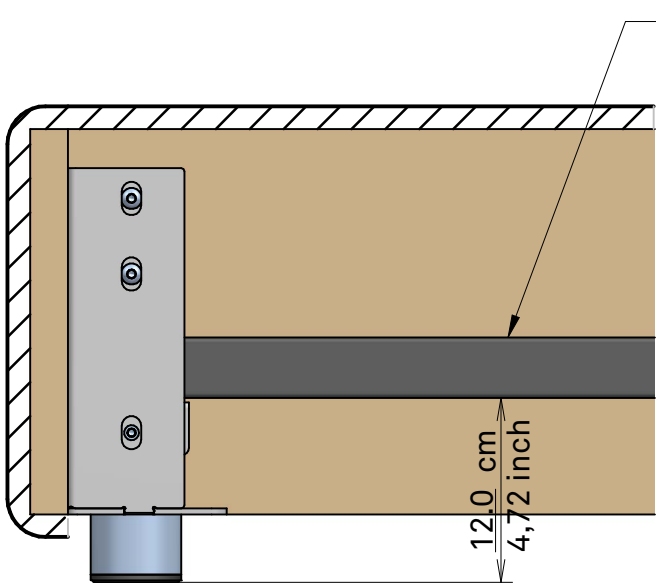

13

2c

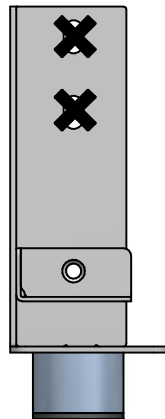
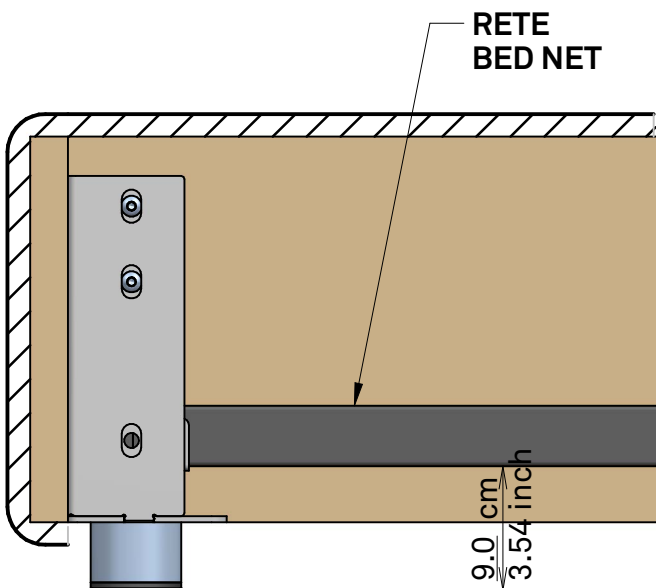

20

3a

n° 08 TBCE M8x25 ZB.



n° 08 ø8x24 ZB.

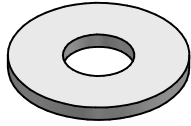

n° 04 TPSCE M8x25 ZB.

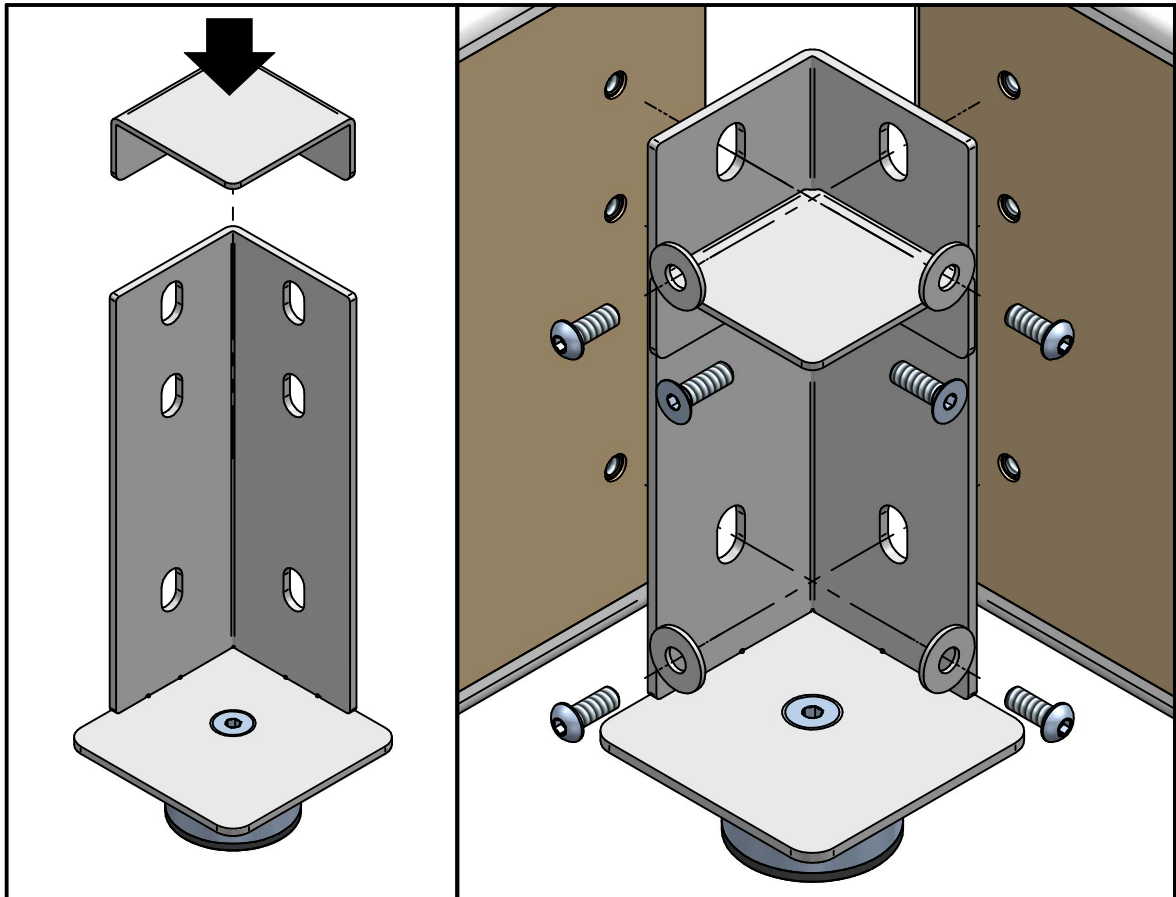
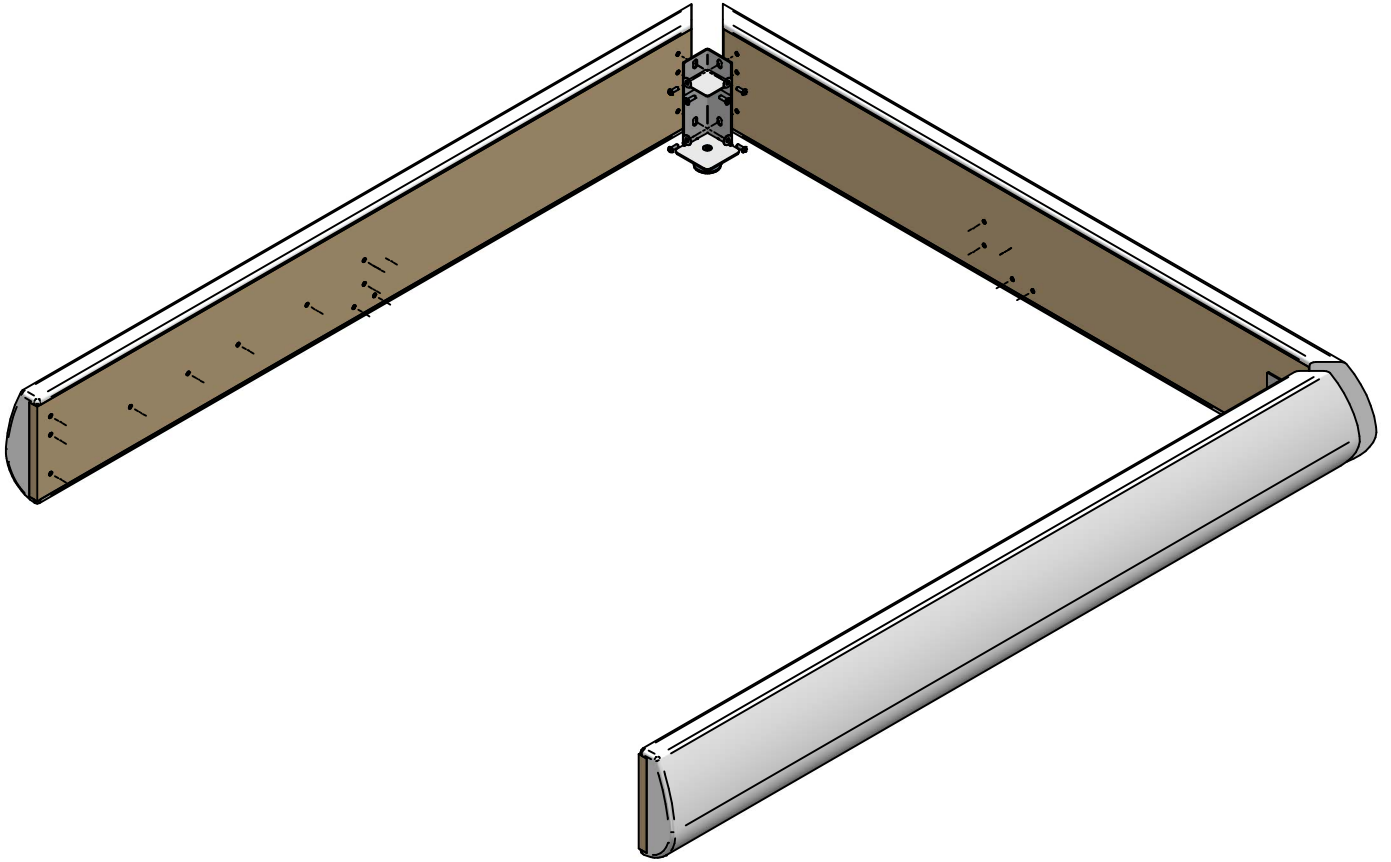



1) Posizionare il rivestimento sul giroletto partendo dalla parte dx della pediera, facendo attenzione che l'etichetta posta sul lato interno del rivestimento sia situata verso il basso e bloccandolo nella parte interna in corrispondenza degli angoli togliendo una parte di coprivelcro;

Position the coating on the bed frame starting from the right of the footboard, making sure that the label on the inner side of the coating is situated downwards, and locking it in the inner part at the corners by removing a part of velcro cover;



2) Sistemare il rivestimento facendo combaciare perfettamente gli angoli della pediera;

Place the cover, lining up perfectly corners of the footboard;

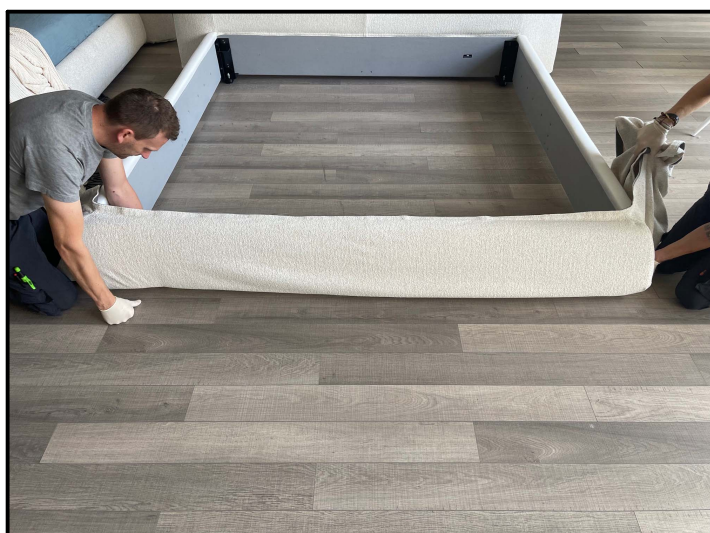

3) Fissare il rivestimento nella parte interna in corrispondenza degli angoli togliendo una parte di coprivelcro;

Fix the coating on the inside at the corners by removing a part of velcro cover;

5a

4) Posizionare il rivestimento sul longone, togliere il coprivelcro dalla parte finale e fissarlo facendo attenzione affinché i bordi del longone combacino con quelli del rivestimento su entrambi i lati;

Place the coating on the longone, remove the velcro cover from the final part and fix it being careful so that the edges of the longone matching those of the coating on both sides;



5) Togliere il coprivelcro dalla parte superiore dei longoni e della pediera, mentre si fissa all'accoppiato;

Remove the velcro cover from the top of the side members and the footboard, while fixed all'accoppiato;



6) Eseguire la medesima operazione nella parte inferiore del rivestimento accompagnando il tessuto verso il basso e fissandolo;

Perform the same operation in the lower part of the coating accompanying the fabric down and securing it;



7) Tenere il coprivelcro e non buttarlo via in modo da poterlo applicare nel rivestimento per il lavaggio.

Keep the velcro cover and do not throw it away, so that you can put it back on while washing the cover.



n° 08 TBCE M8x25 ZB.

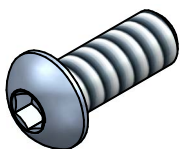

n° 08 ø8x24 ZB.

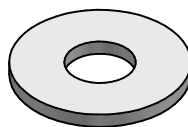

n° 04 TPSCE M8x25 ZB.

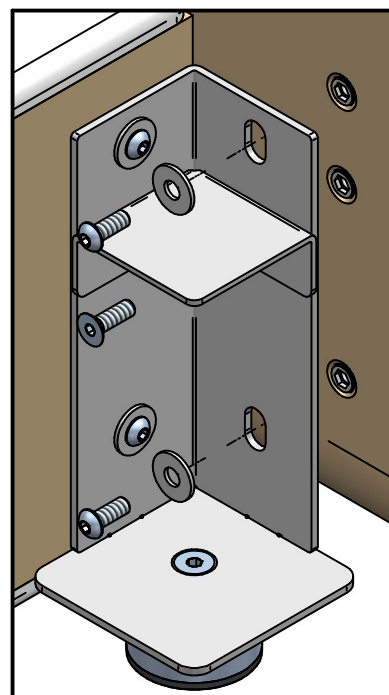
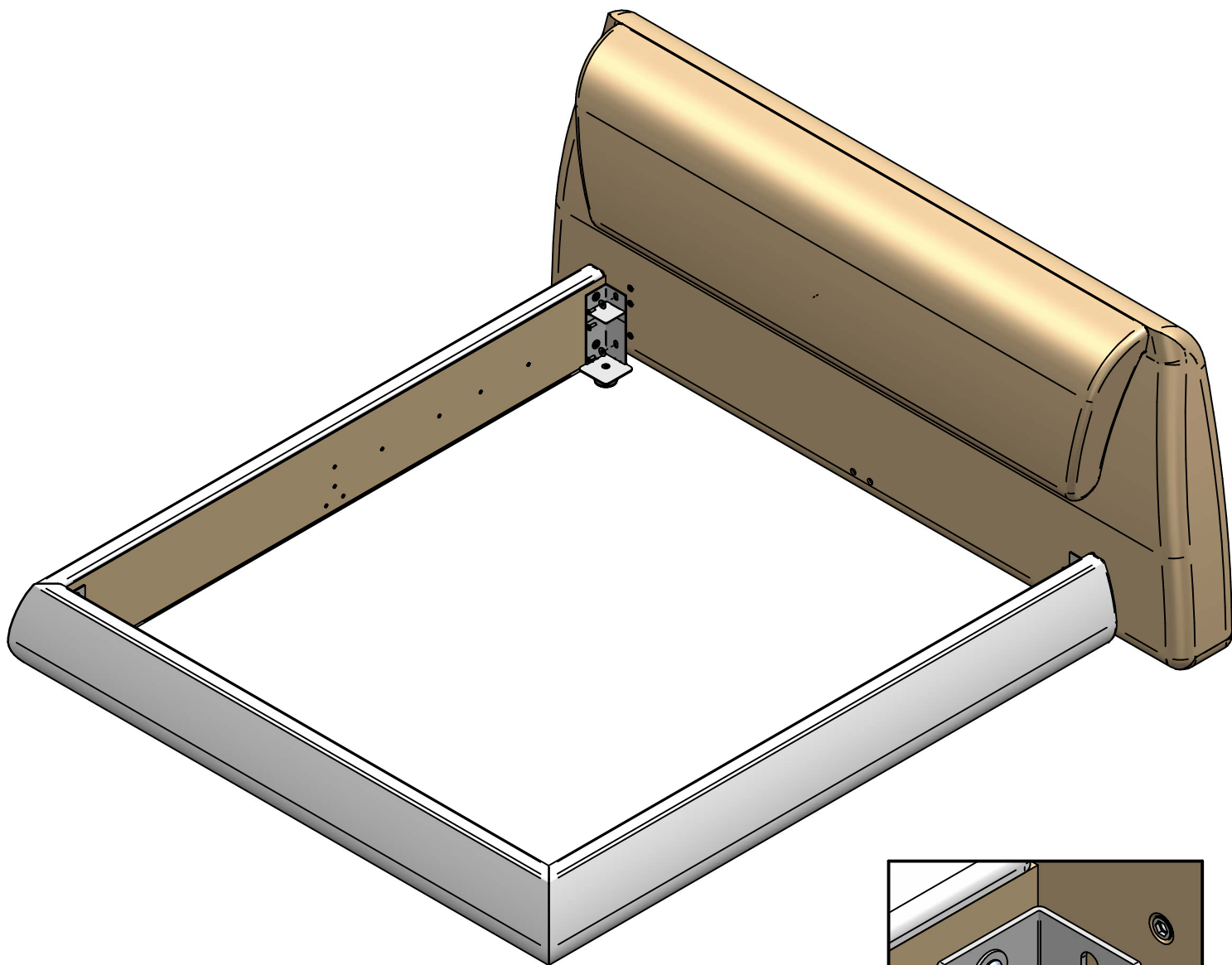
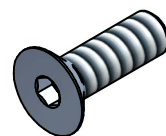

7a

n° 03 TTDE M8x70 ZB.



n° 03 M8 medio ZB.

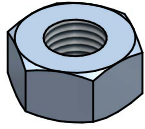

n° 03 ø8x32 ZB.

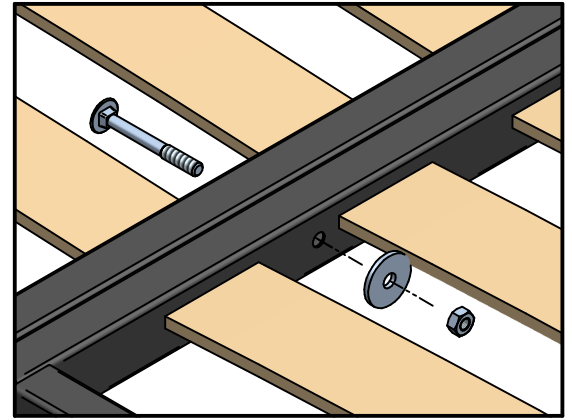
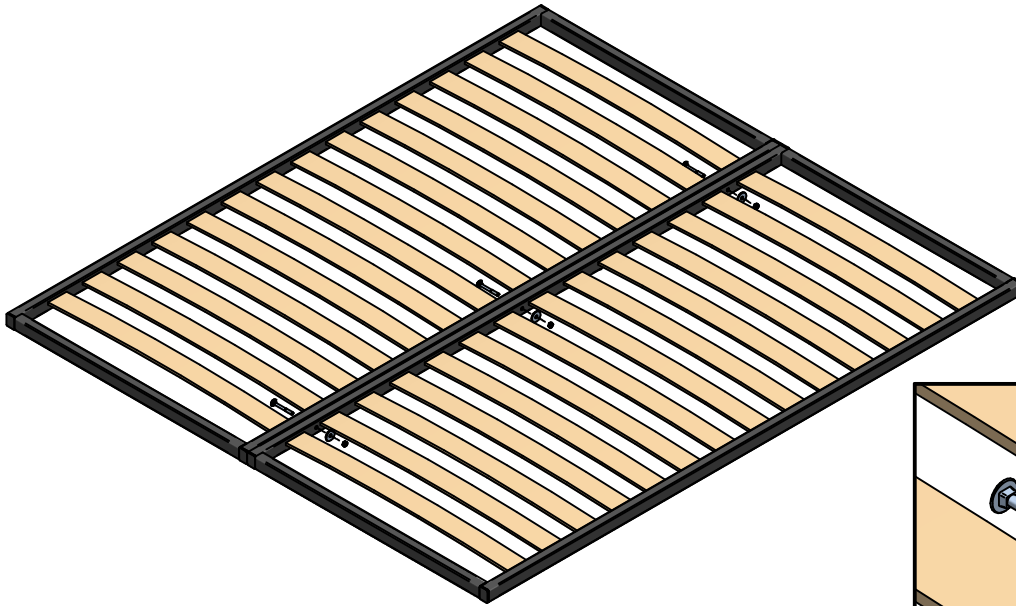
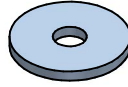

8a

n° 04 TBCE M8x25 ZB.

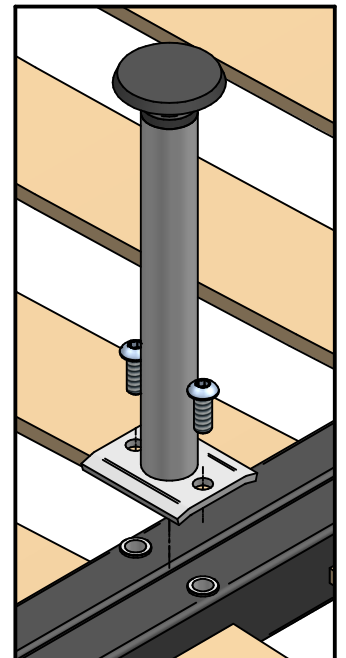
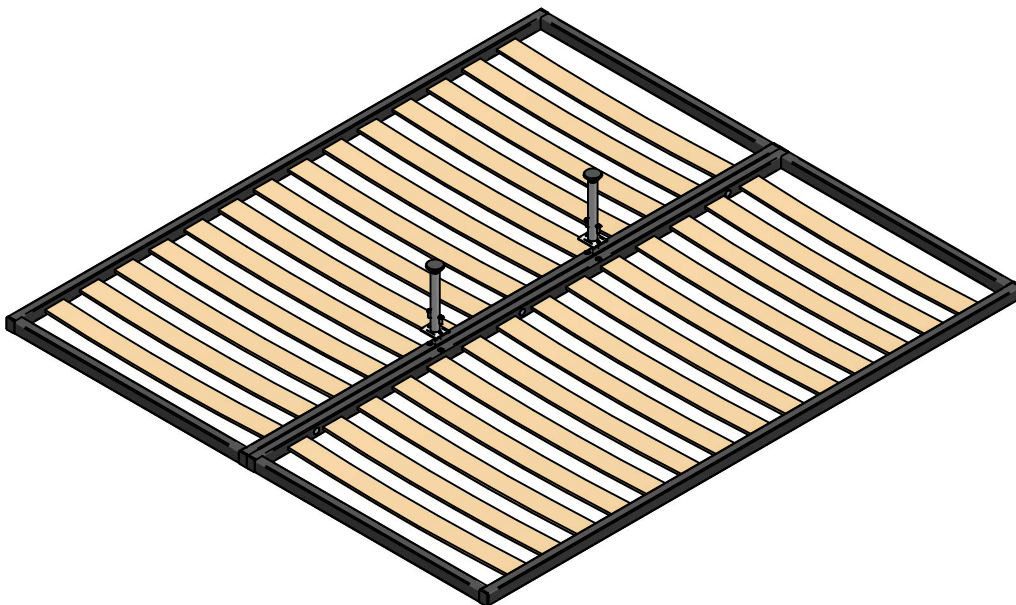

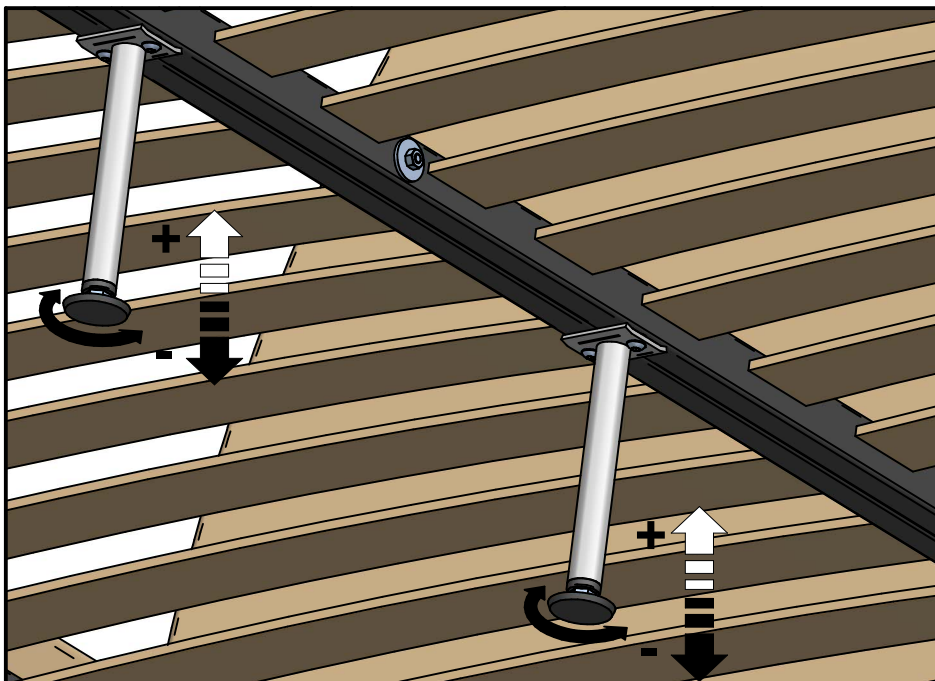
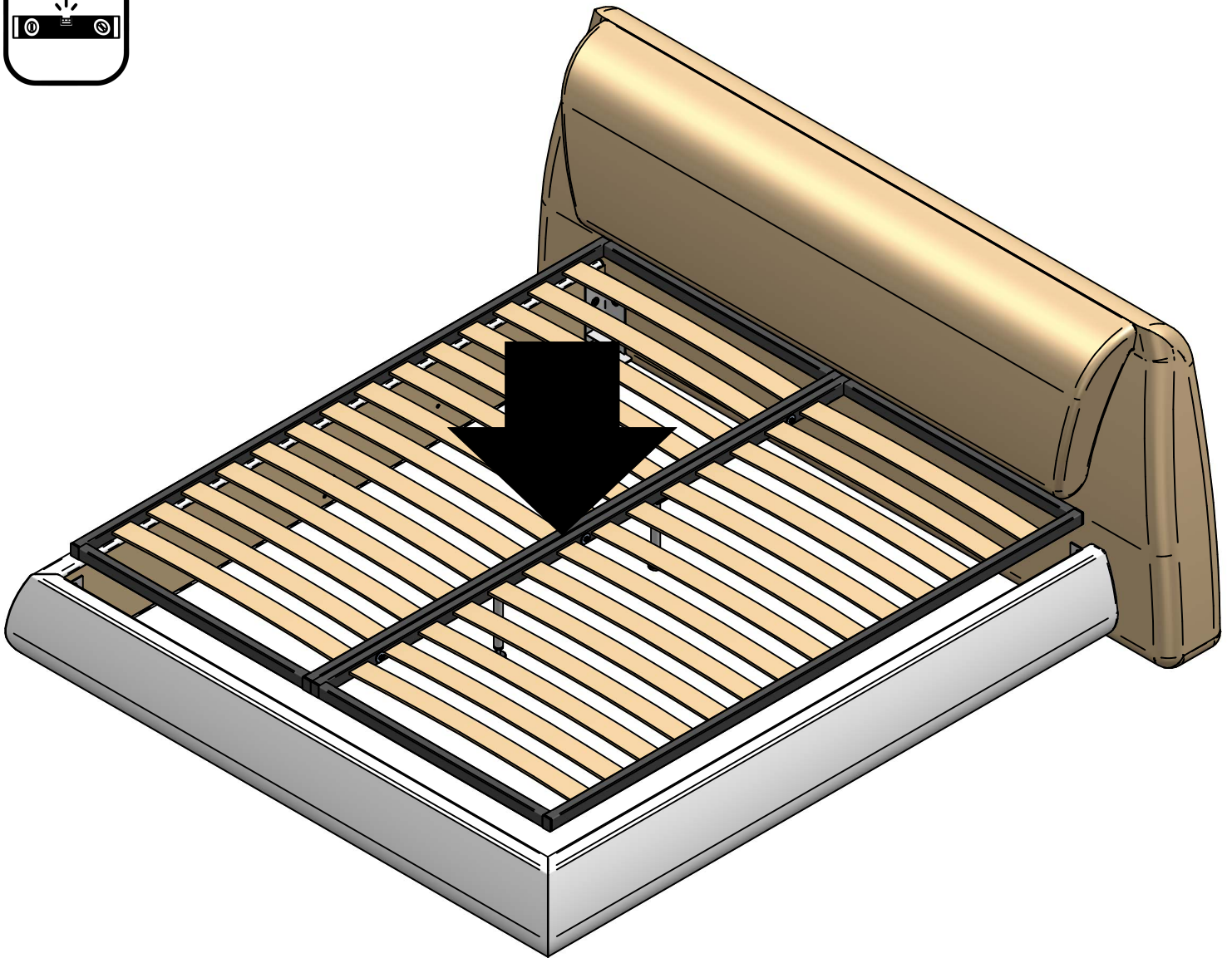
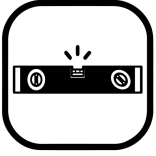

n° 08 TBCE M8x25 ZB.

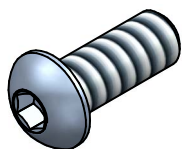

n° 08 ø8x24 ZB.

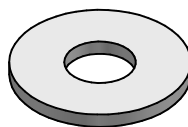

n° 04 TPSCE M8x25 ZB.

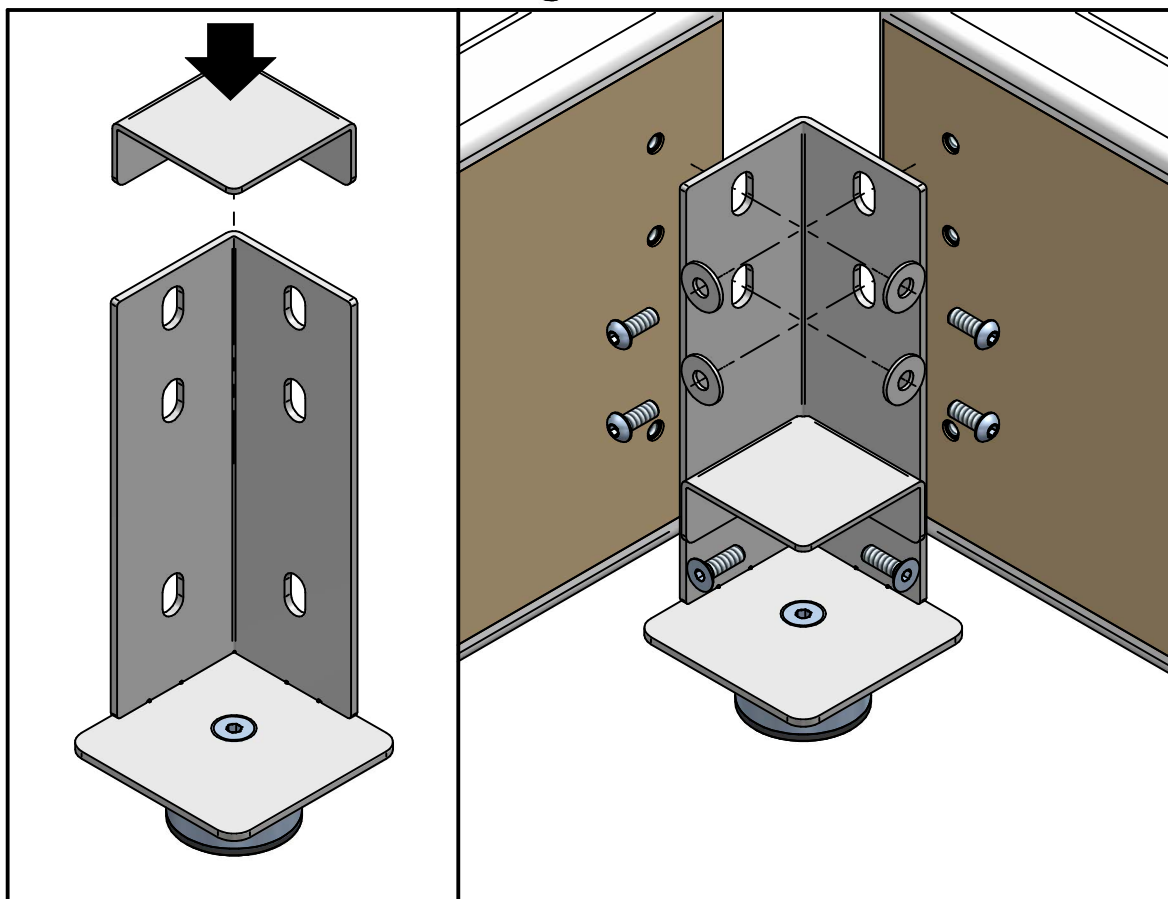
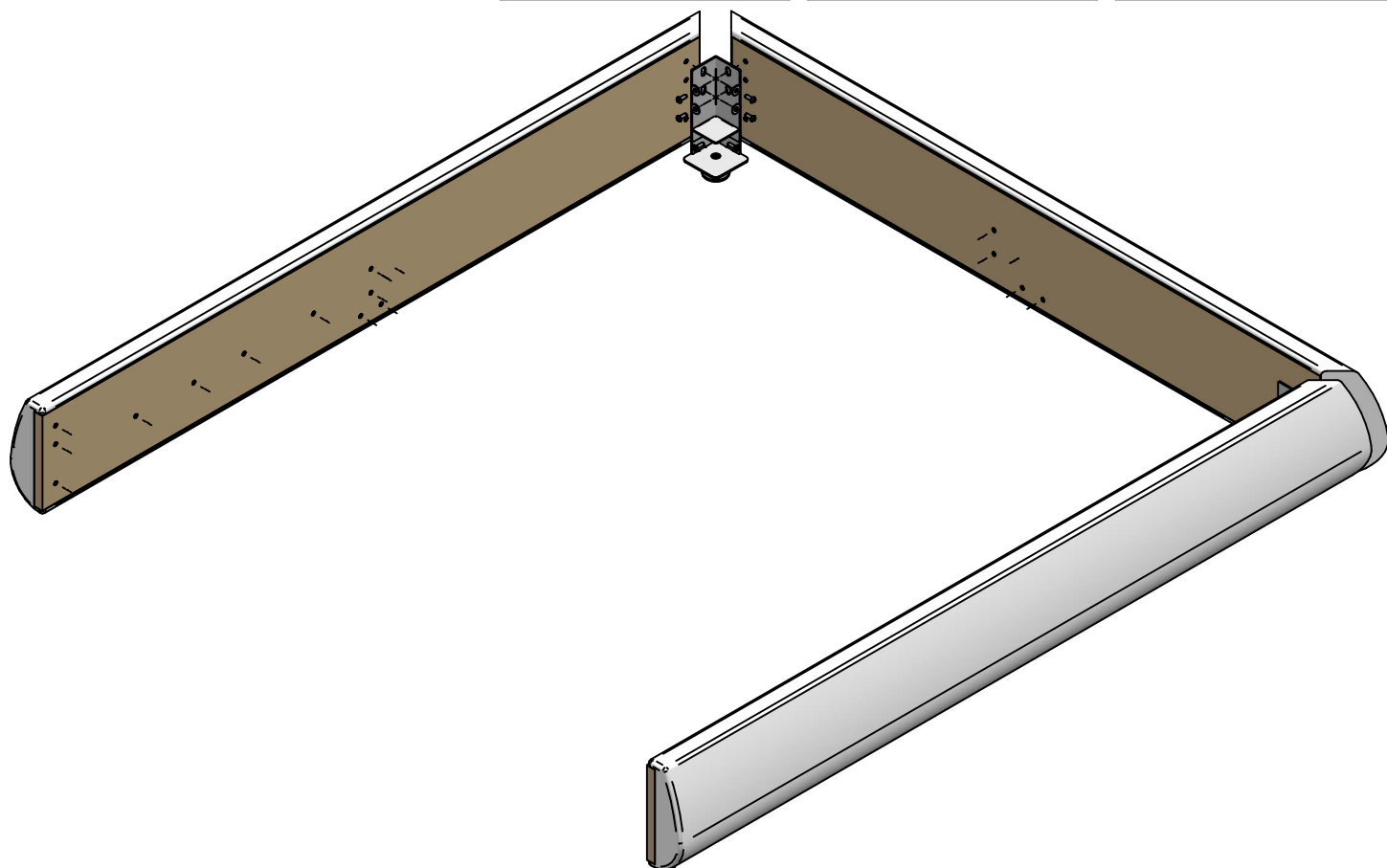
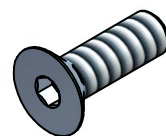

1) Posizionare il rivestimento sul giroletto partendo dalla parte dx della pediera, facendo attenzione che l'etichetta posta sul lato interno del rivestimento sia situata verso il basso e bloccandolo nella parte interna in corrispondenza degli angoli togliendo una parte di coprivelcro;

Position the coating on the bed frame starting from the right of the footboard, making sure that the label on the inner side of the coating is situated downwards, and locking it in the inner part at the corners by removing a part of velcro cover;

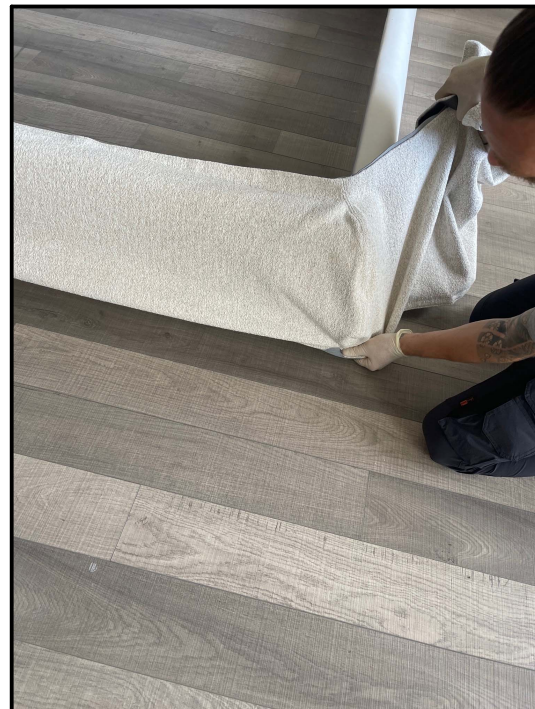

2) Sistemare il rivestimento facendo combaciare perfettamente gli angoli della pediera;

Place the cover, lining up perfectly corners of the footboard;



3) Fissare il rivestimento nella parte interna in corrispondenza degli angoli togliendo una parte di coprivelcro;

Fix the coating on the inside at the corners by removing a part of velcro cover;

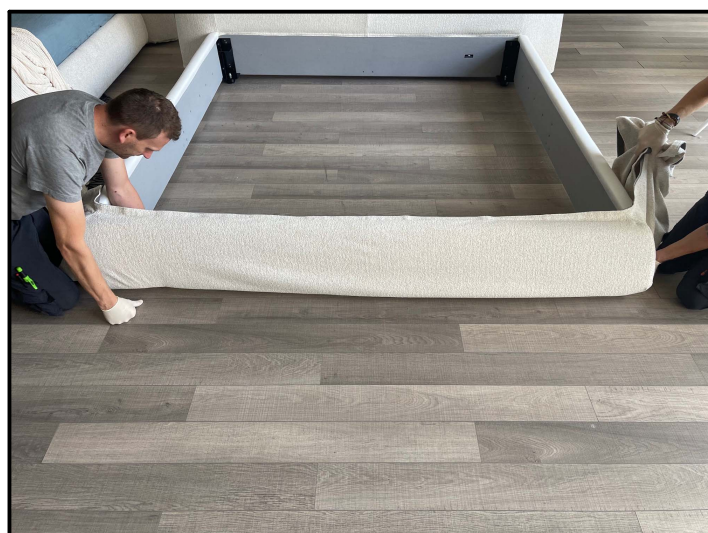



4) Posizionare il rivestimento sul longone, togliere il coprivelcro dalla parte finale e fissarlo facendo attenzione affinché i bordi del longone combacino con quelli del rivestimento su entrambi i lati;

Place the coating on the longone, remove the velcro cover from the final part and fix it being careful so that the edges of the longone matching those of the coating on both sides;

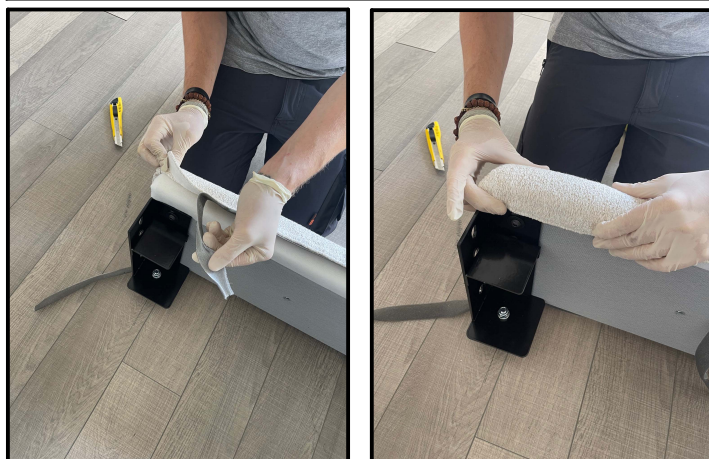

5) Togliere il coprivelcro dalla parte superiore dei longoni e della pediera, mentre si fissa all'accoppiato;

Remove the velcro cover from the top of the side members and the footboard, while fixed all'accoppiato;



6) Eseguire la medesima operazione nella parte inferiore del rivestimento accompagnando il tessuto verso il basso e fissandolo;

Perform the same operation in the lower part of the coating accompanying the fabric down and securing it;



7) Tenere il coprivelcro e non buttarlo via in modo da poterlo applicare nel rivestimento per il lavaggio.

Keep the velcro cover and do not throw it away, so that you can put it back on while washing the cover.

6b

n° 08 TBCE M8x25 ZB.



n° 08 ø8x24 ZB.

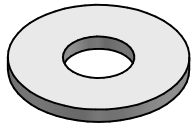

n° 04 TPSCE M8x25 ZB.

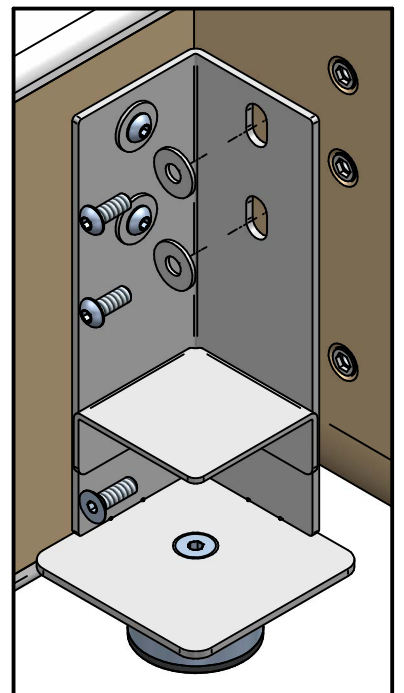
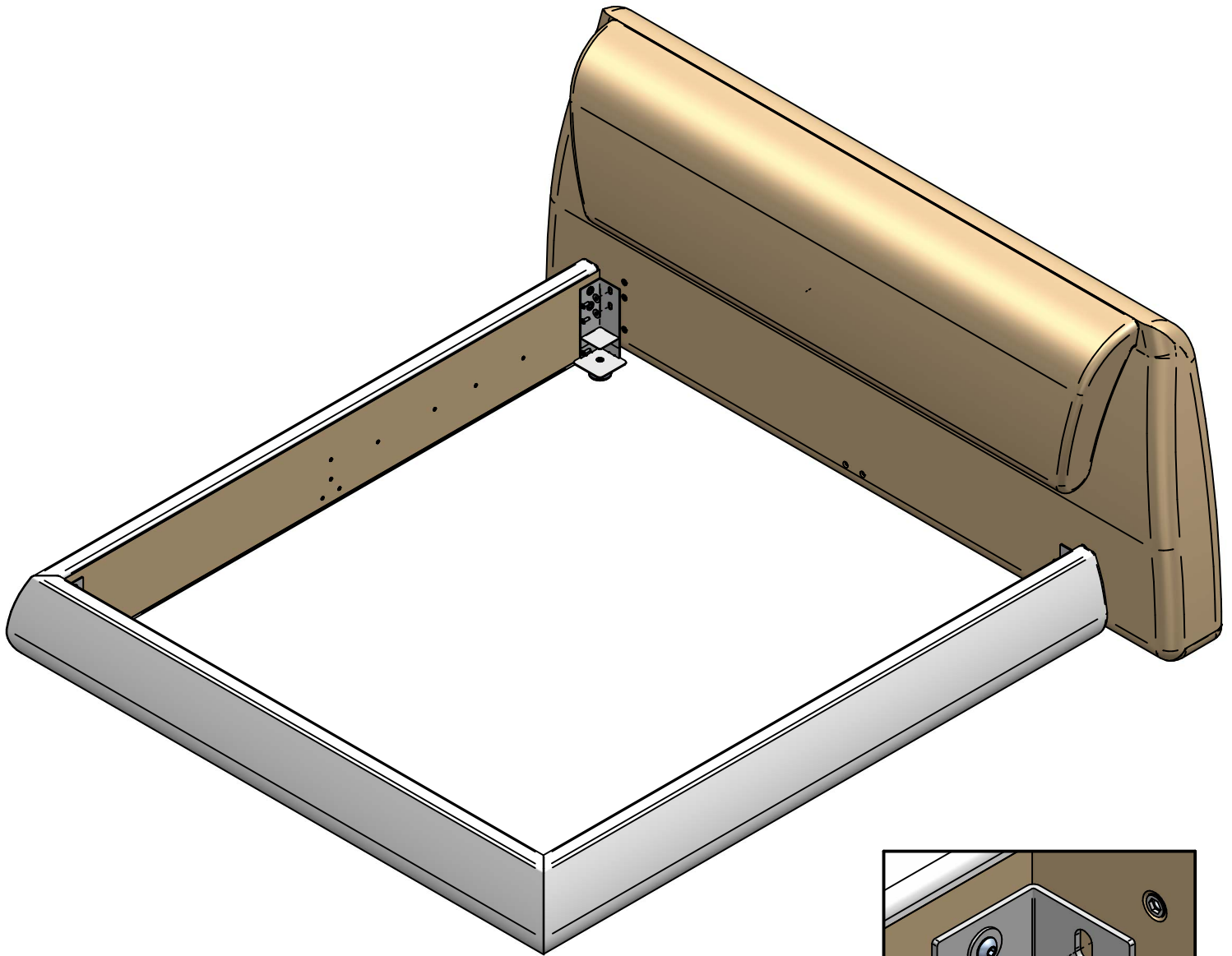

n° 03 TTDE M8x70 ZB.



n° 03 M8 medio ZB.

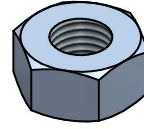

n° 03 ø8x32 ZB.

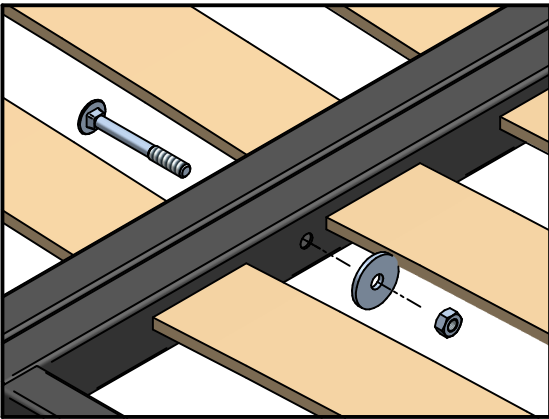
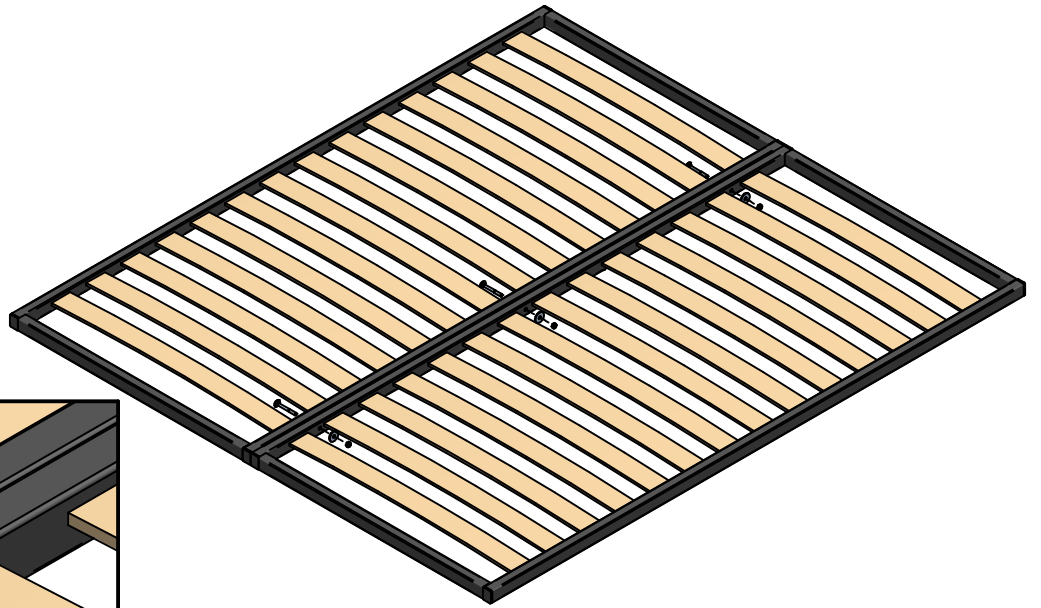
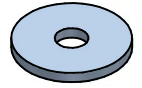

n° 04 TBCE M8x25 ZB.



n° 02 pz.

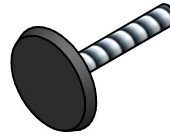

n° 02 M10 medio ZB.

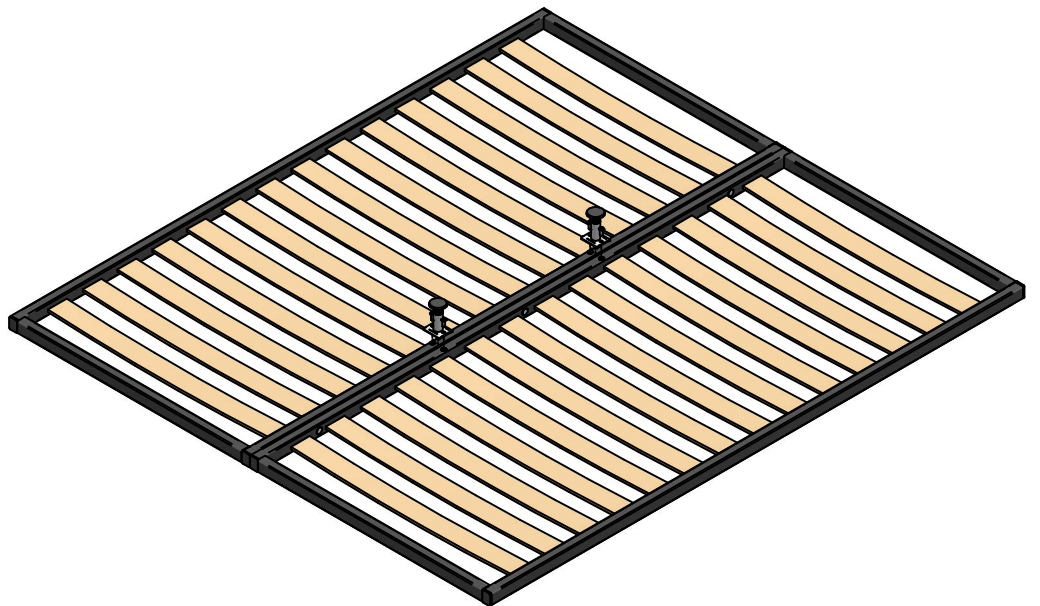
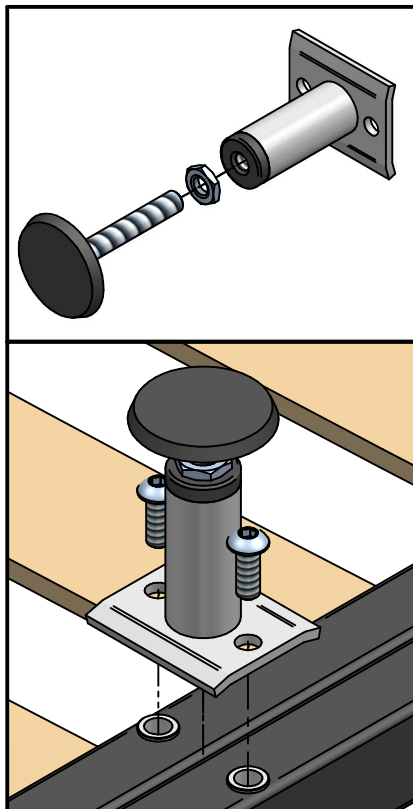
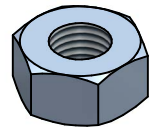

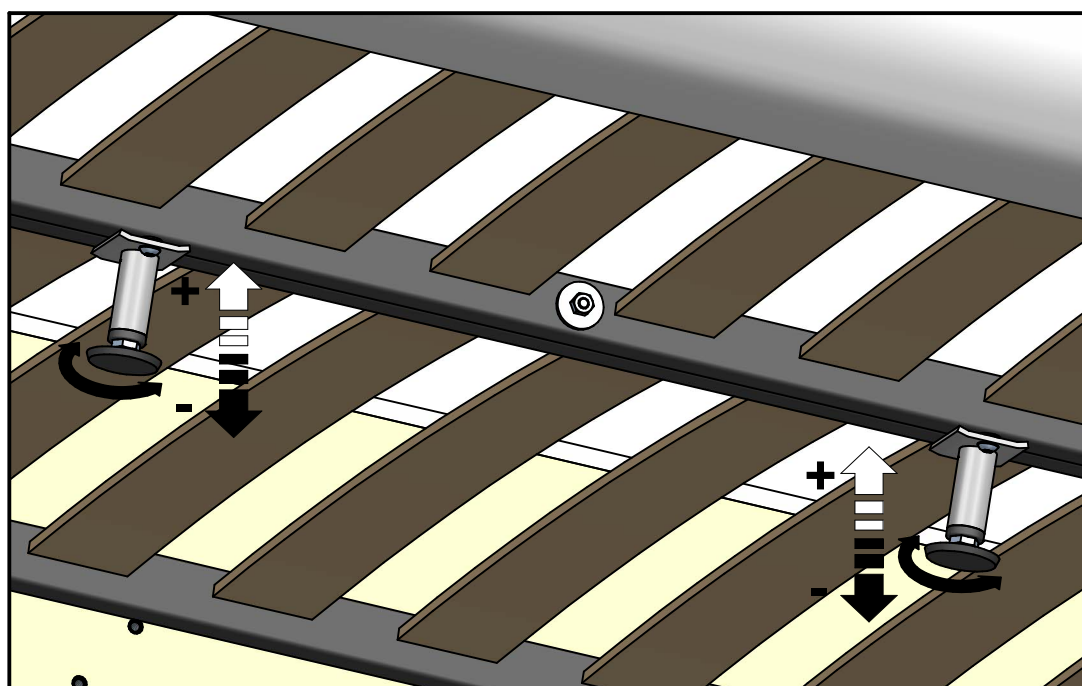
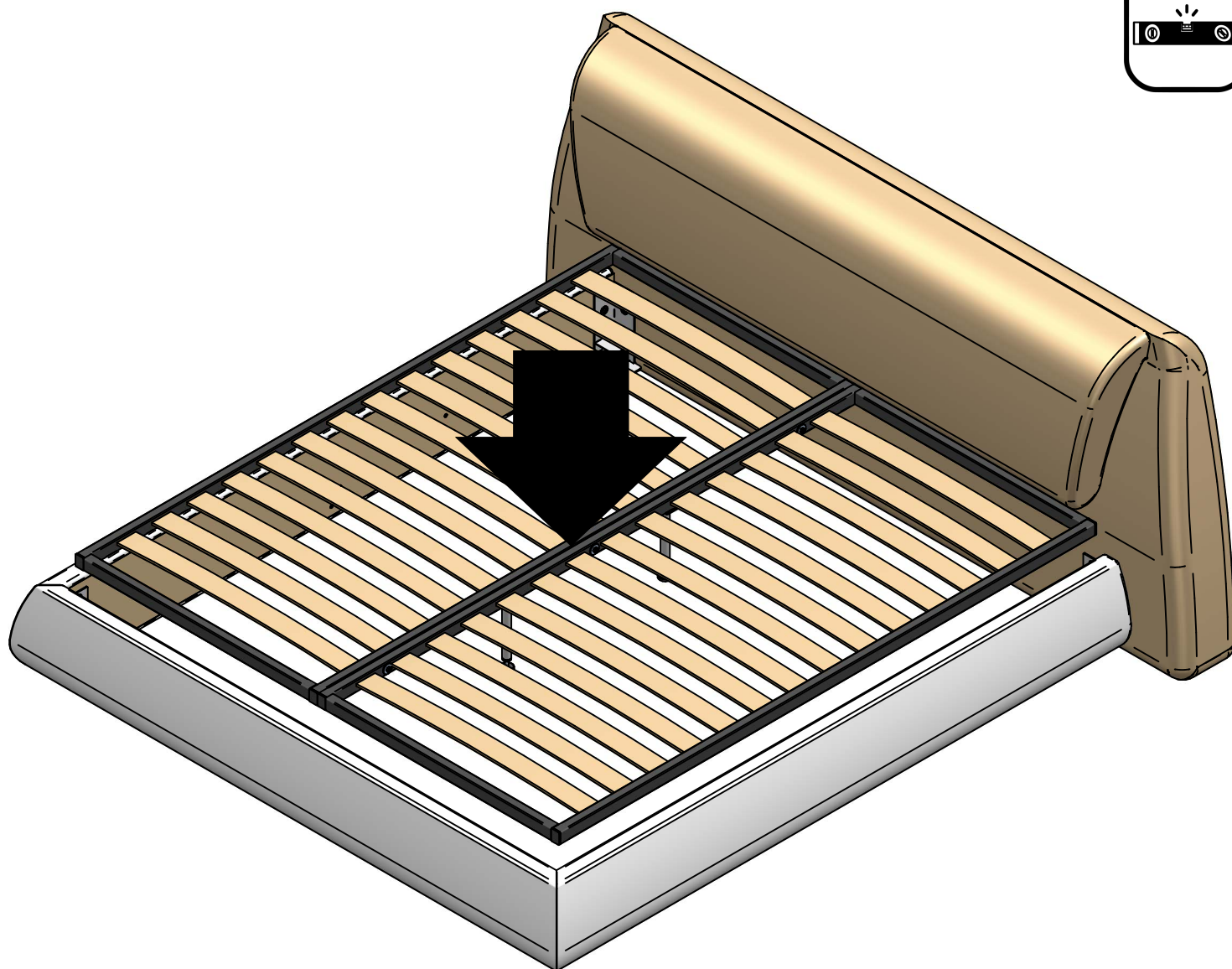
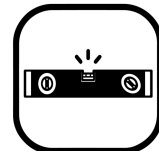

3c

n° 08 TBCE M8x25 ZB.



n° 08 ø8x24 ZB.

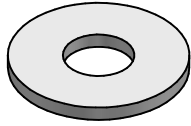

n° 04 TPSCE M8x25 ZB.

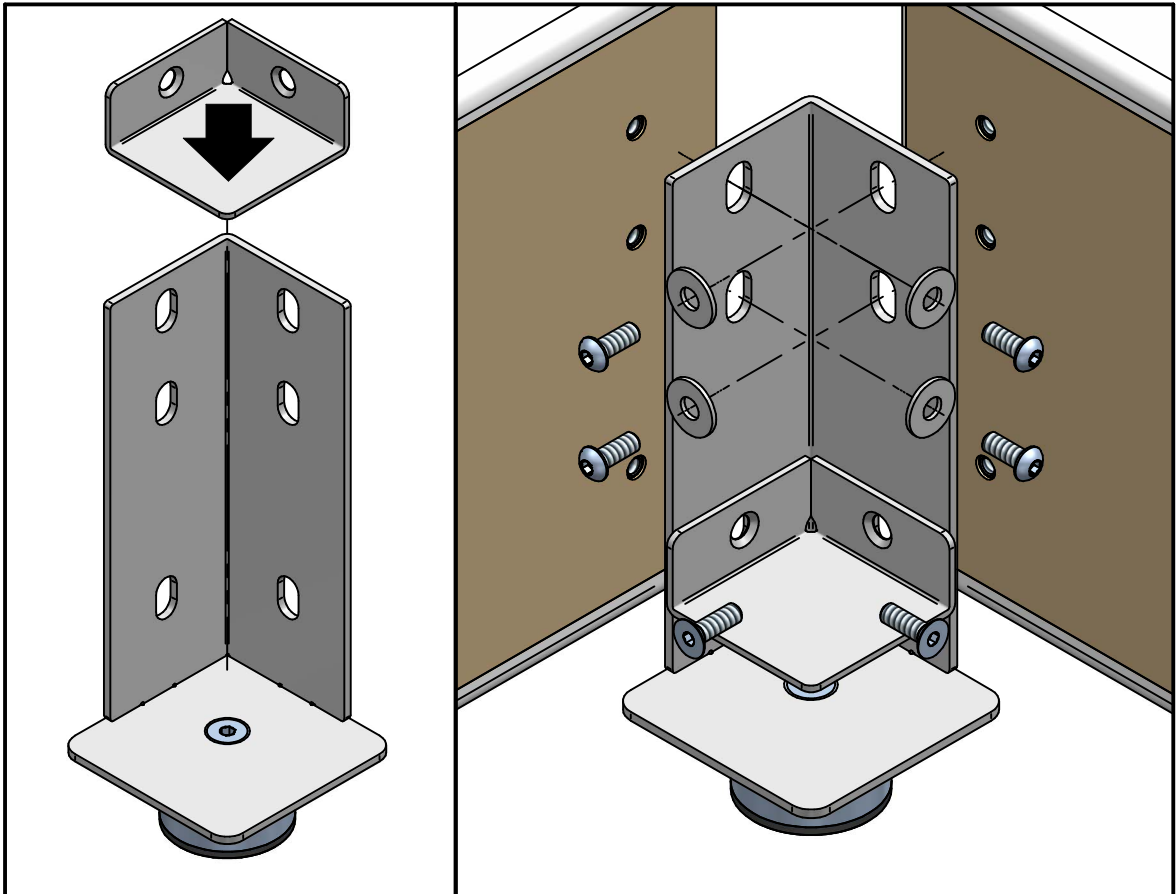
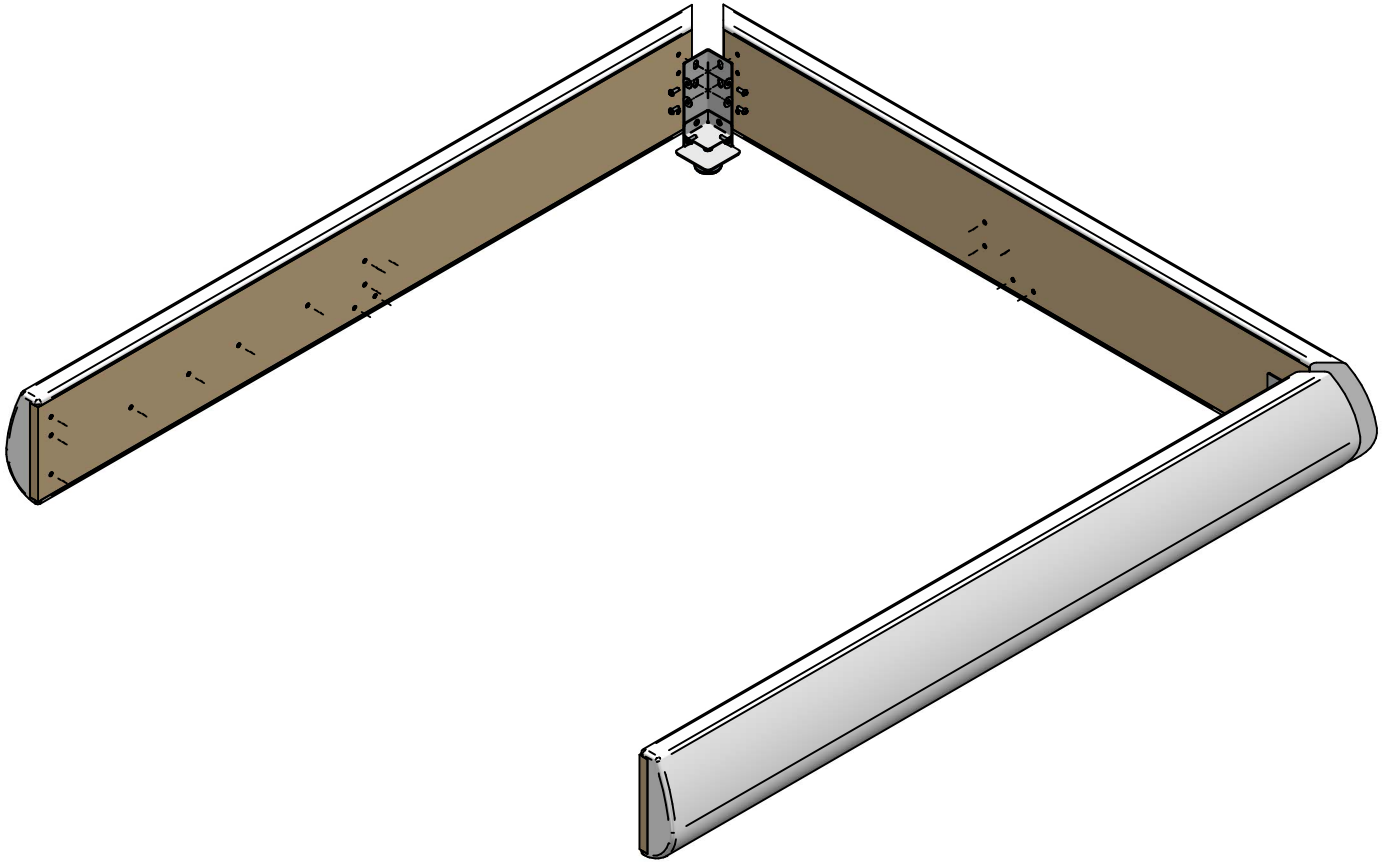



1) Posizionare il rivestimento sul giroletto partendo dalla parte dx della pediera, facendo attenzione che l'etichetta posta sul lato interno del rivestimento sia situata verso il basso e bloccandolo nella parte interna in corrispondenza degli angoli togliendo una parte di coprivelcro;

Position the coating on the bed frame starting from the right of the footboard, making sure that the label on the inner side of the coating is situated downwards, and locking it in the inner part at the corners by removing a part of velcro cover;



2) Sistemare il rivestimento facendo combaciare perfettamente gli angoli della pediera;

Place the cover, lining up perfectly corners of the footboard;

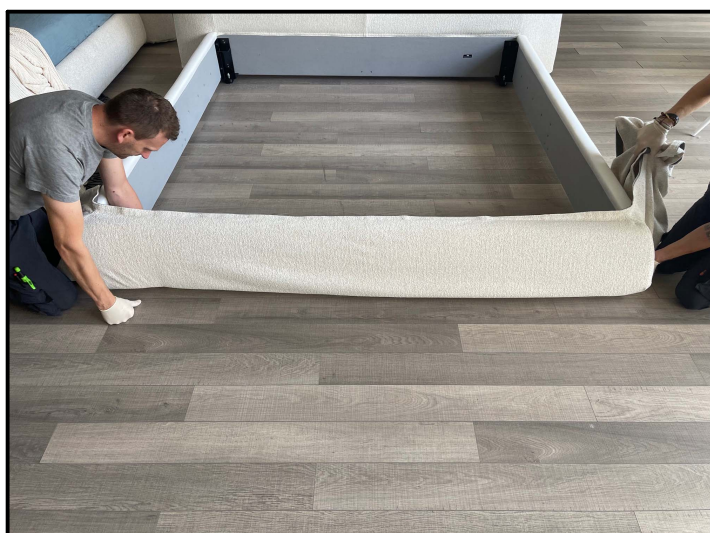

3) Fissare il rivestimento nella parte interna in corrispondenza degli angoli togliendo una parte di coprivelcro;

Fix the coating on the inside at the corners by removing a part of velcro clover;

5c

4) Posizionare il rivestimento sul longone, togliere il coprivelcro dalla parte finale e fissarlo facendo attenzione affinché i bordi del longone combacino con quelli del rivestimento su entrambi i lati;

Place the coating on the longone, remove the velcro cover from the final part and fix it being careful so that the edges of the longone matching those of the coating on both sides;



5) Togliere il coprivelcro dalla parte superiore dei longoni e della pediera, mentre si fissa all'accoppiato;

Remove the velcro cover from the top of the side members and the footboard, while fixed all'accoppiato;



6) Eseguire la medesima operazione nella parte inferiore del rivestimento accompagnando il tessuto verso il basso e fissandolo;

Perform the same operation in the lower part of the coating accompanying the fabric down and securing it;



7) Tenere il coprivelcro e non buttarlo via in modo da poterlo applicare nel rivestimento per il lavaggio.

Keep the velcro cover and do not throw it away, so that you can put it back on while washing the cover.



n° 08 TBCE M8x25 ZB.

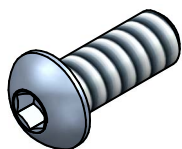

n° 08 ø8x24 ZB.

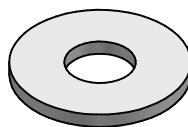

n° 04 TPSCE M8x25 ZB.

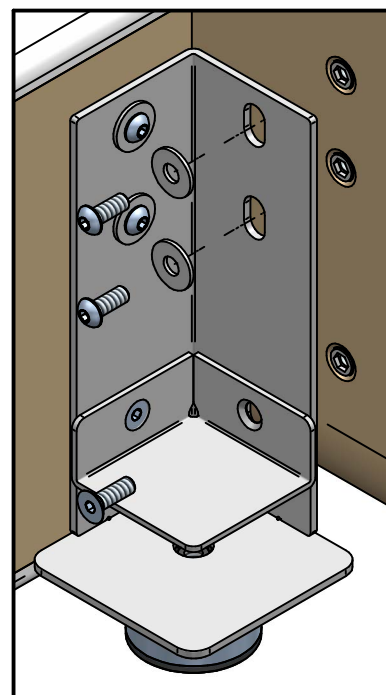
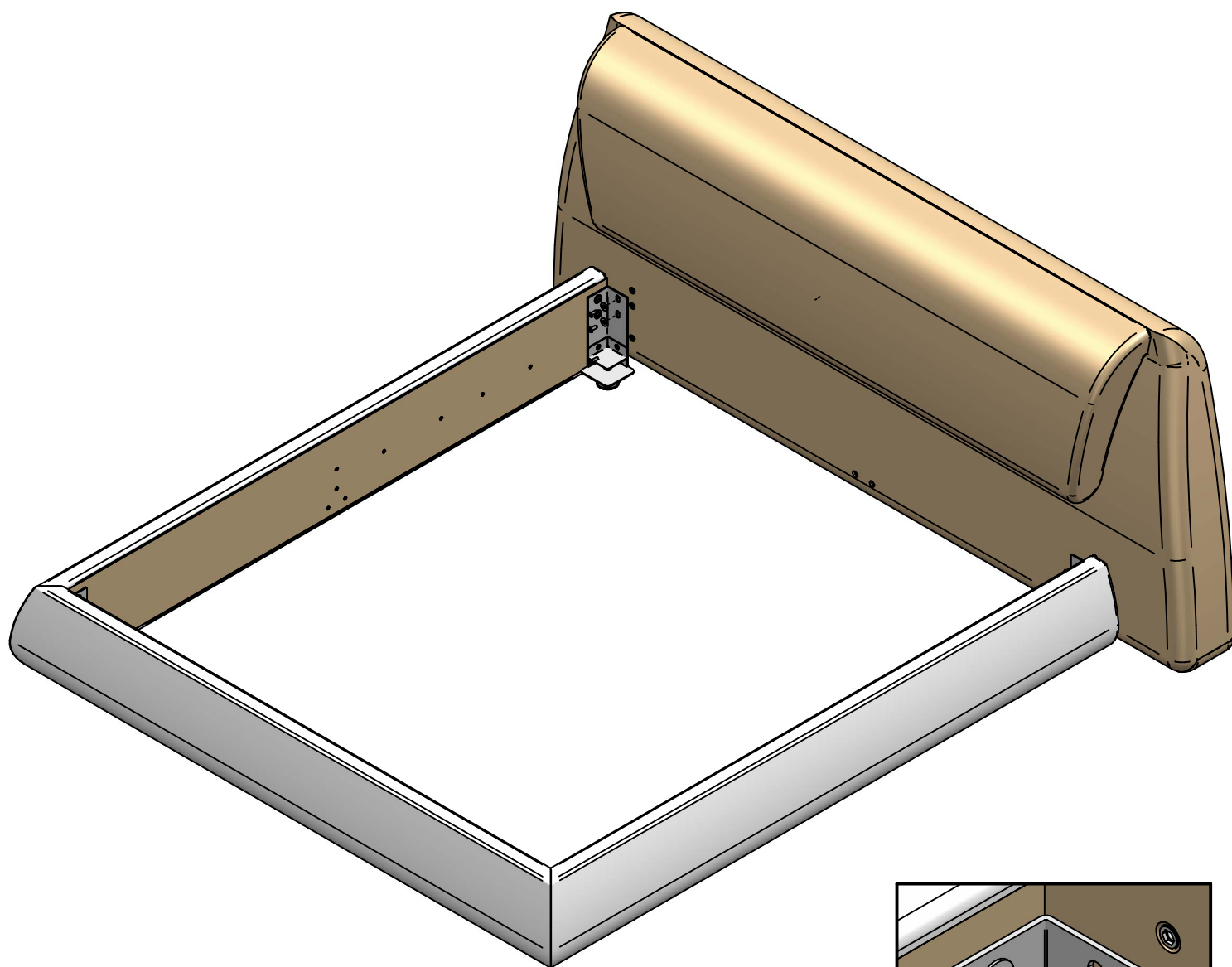
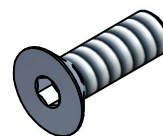

7c

n° 03 TTDE M8x70 ZB.



n° 03 M8 medio ZB.

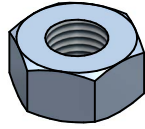

n° 03 ø8x32 ZB.

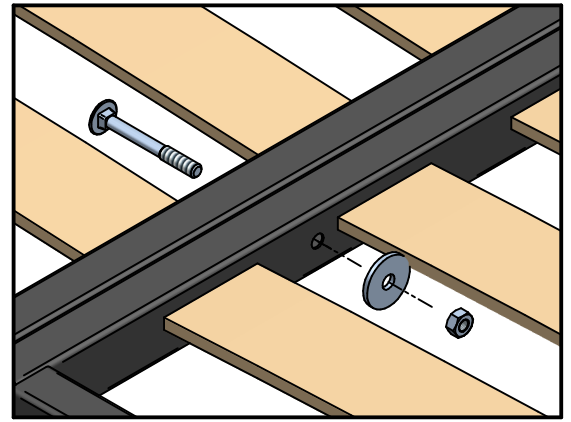
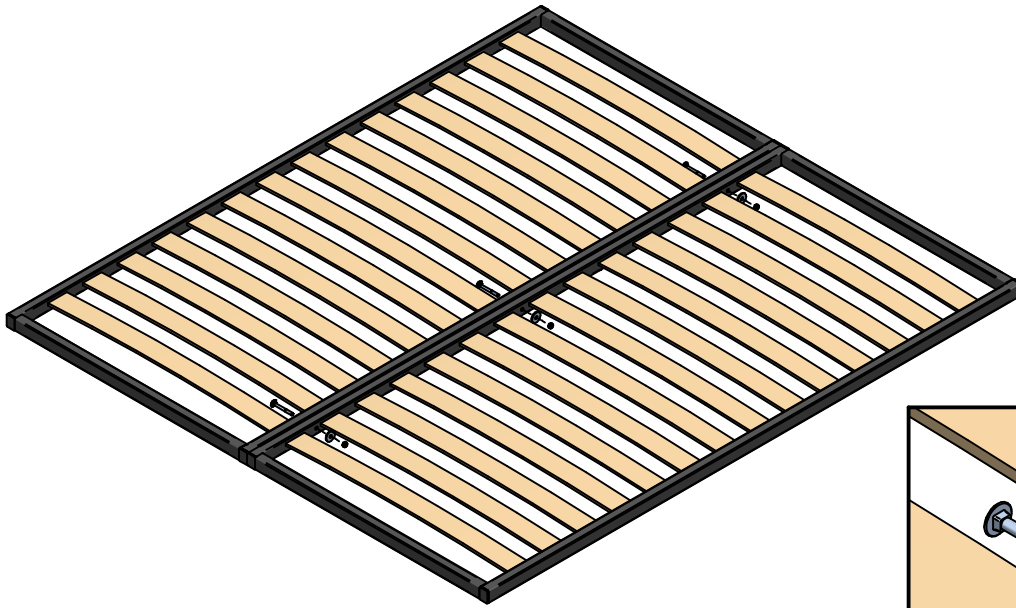
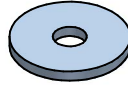

8c

n° 04 TBCE M8x25 ZB.



n° 02 pz.

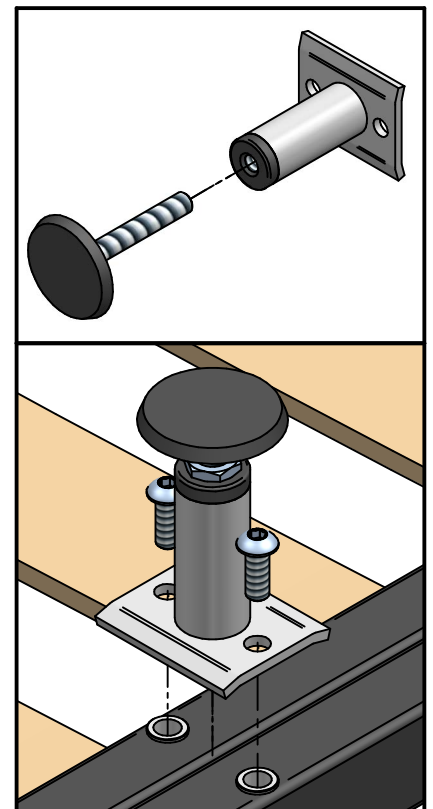
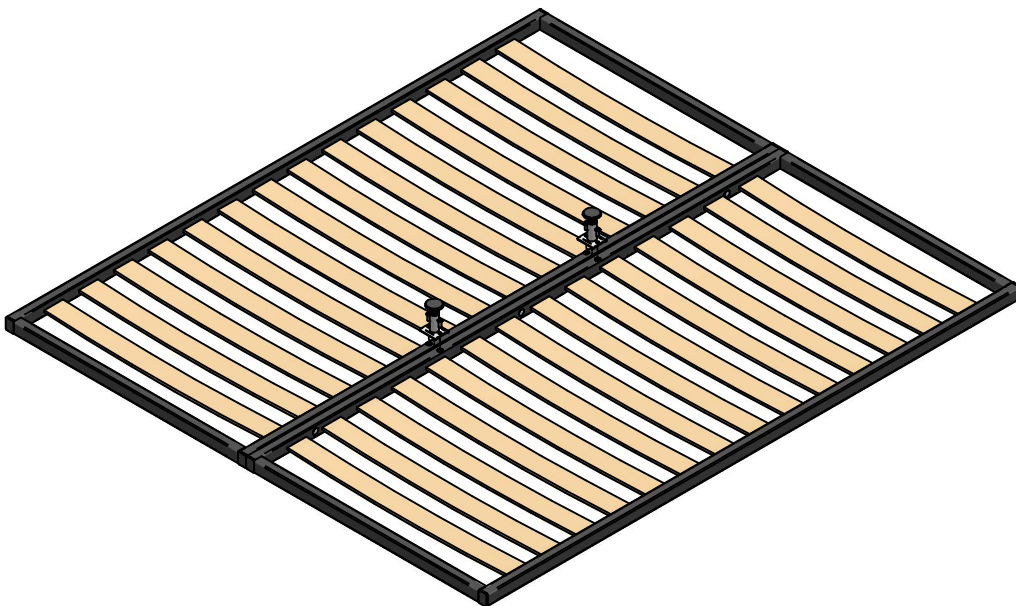
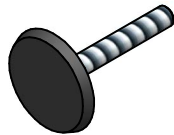

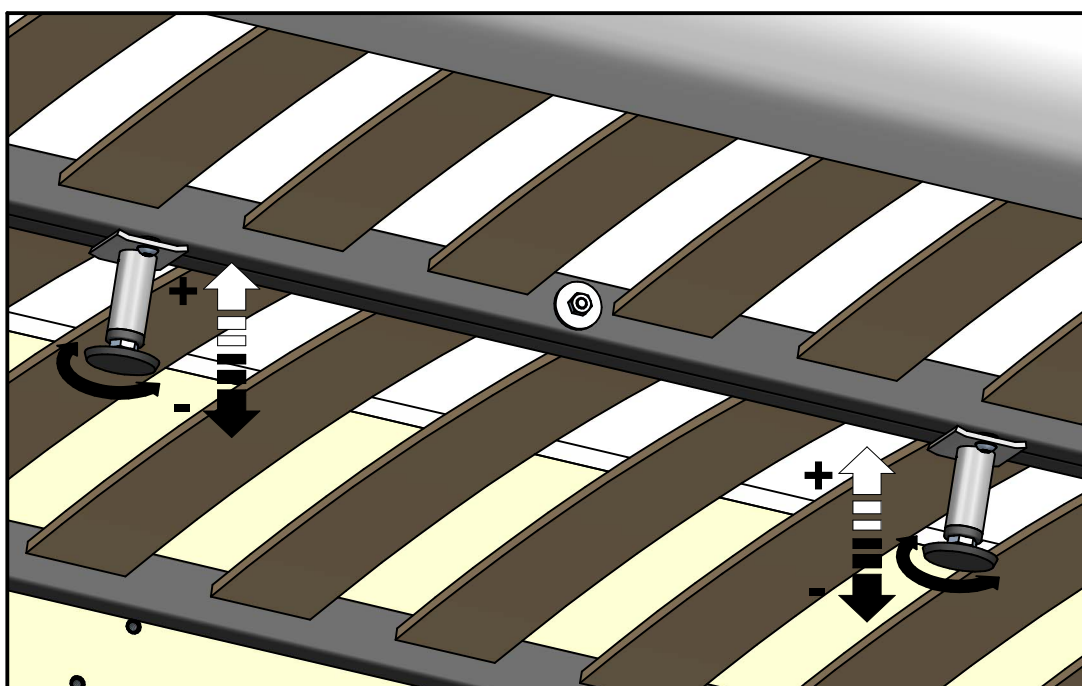
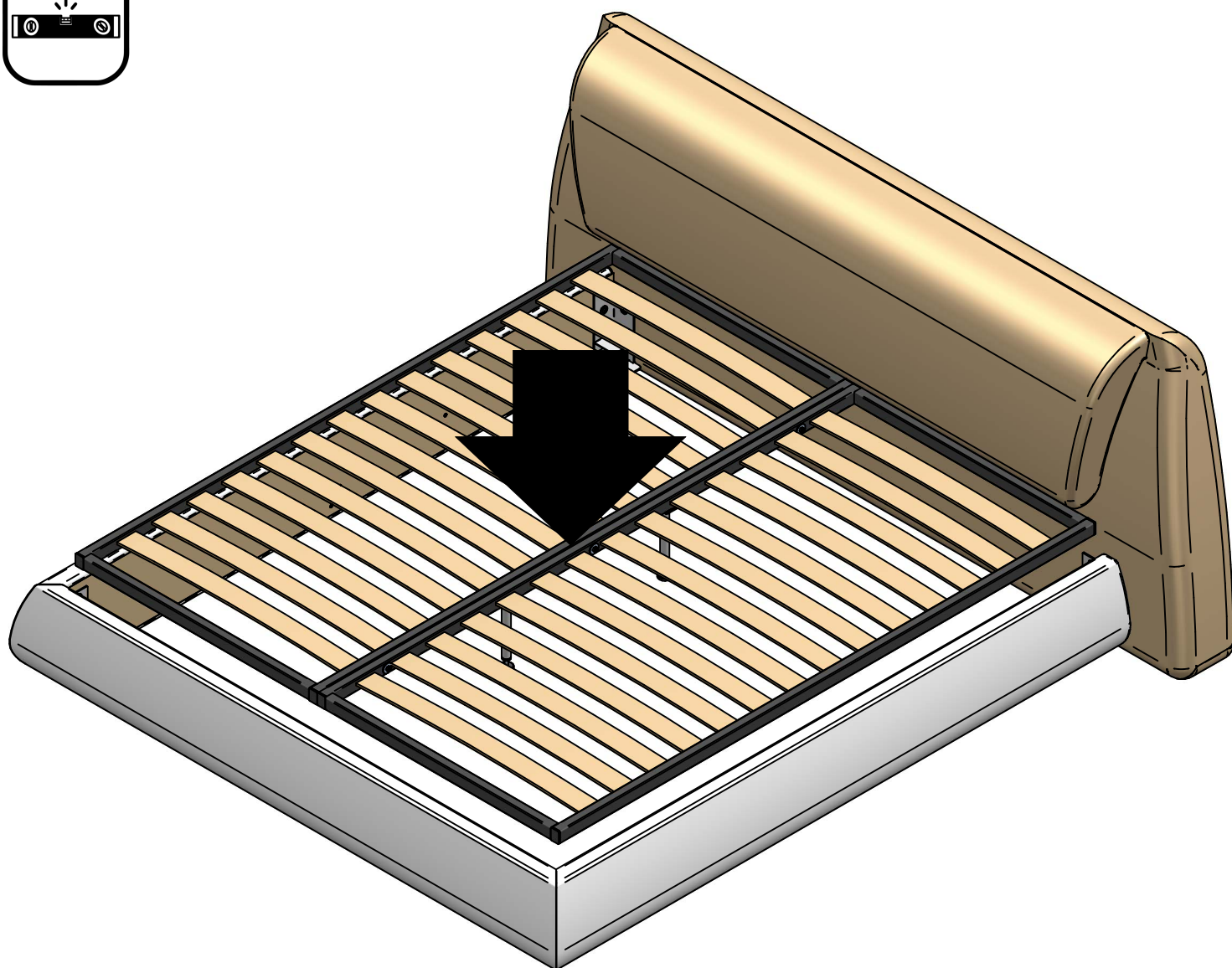

IT**USO**

Il prodotto è destinato per l'utilizzo all'interno delle abitazioni con l'uso per il quale è stato realizzato.

REALIZZAZIONE

Piccole irregolarità sulla base sono dovute alla lavorazione manuale del prodotto.

ATTENZIONE

Non spostare assolutamente mai il prodotto trascinandolo o sollevandolo prendendolo per il piano ma smontarlo e riposizionarlo dove voluto, assicurandosi di proteggere le parti che si potrebbero danneggiare.

SMALTIMENTO

Una volta dismesso, il prodotto od i suoi componenti non vanno dispersi nell'ambiente ma conferiti ai sistemi pubblici di smaltimento.

MANUTENZIONE

Non vanno assolutamente utilizzati strumenti metallici appuntiti o panni abrasivi per eliminare eventuali residui di sporco presenti sulla superficie del prodotto, in quanto possono danneggiare la superficie stessa. Non vanno assolutamente utilizzati detergenti che contengano cloro o a base di acido cloridrico, acido muriatico o prodotti anticalcare in quanto andrebbero ad alterare la brillantezza del prodotto.

MANUTENZIONE PELLE

Per la normale pulizia spolverare con un panno morbido e asciutto. Eventuali macchie si possono eliminare trattandole con un panno o cotone idrofilo umido, e prodotti per la pulizia inizialmente più delicati quali sapone neutro o latte detergente. Asciugare immediatamente dopo il trattamento. Evitare di strofinare la superficie da trattare, ma tamponare, dai bordi verso il centro della macchia. Non usare mai prodotti abrasivi o aggressivi quali solventi, smacchiatori, ecc. Non usare mai il vapore. Non utilizzare i prodotti per la pulizia delle scarpe.

In ogni caso, ogni volta che si utilizza un prodotto nuovo per la pulizia, applicarlo in una zona "nascosta", per verificare l'efficacia ed evitare il danneggiamento di zone più esposte.

EN**USE**

The product is intended for an indoor use and may only be used for its intended purpose.

ACCOMPLISHMENT

Small irregularities on the base are due to manual processing.

WARNING

Do not move the product by dragging it or lifting it from the top, but reassemble it and place it in the new site, protecting the parts that could be damaged.

DISPOSAL

If your furniture is unusable or unrepairable, neither the product nor its components are to be dispersed in the environment, but rather consigned to public disposal systems.

MAINTENANCE

It is recommended not to use metal sharp tools or abrasive clothes to eliminate dirt from the surface, because they could damage the same. Do not absolutely use detergents containing chlorine, muriatic acid, hydrochloric acid or descale detergents which can damage the surface brilliance.

LEATHER MAINTENANCE

Dust with a soft and dry cloth for the normal cleaning. Stains can be treated with a wet cloth or cotton wool and with products for the cleaning initially more delicate like neutral soap or cleansing milk. Dry immediately after treatment. Avoid to rub the surface to treat, but apply a blotting pad or tissue from the edges toward the center of the stain. Never use abrasive or aggressive products like solvents, stain removers, et cetera.

Never steam it. Don't use shoe cleaning products. In every case, every time that a new product is used for the cleaning, apply it in a "hidden" area to test its effectiveness and to avoid damages where more visible.

DE**NUTZUNG**

Das Produkt ist nur für den Innenbereich gedacht. Der Tisch wurde hergestellt, nur als Esstisch genutzt zu werden.

AUSFÜHRUNG

Kleine Unregelmäßigkeiten auf der Basis sind nicht zu vermeiden, da das Teil per Hand hergestellt wird.

WARTUNG

Niemals scharfe Werkzeuge aus Metall, spitzen Instrumente oder Schleifmittel für die Reinigung der Oberfläche verwenden. Diese Produkte können die Oberfläche beschädigen. Niemals Chemikalien mit chlorhaltigen Salzsäure, Salzsäure oder Kalk-Produkte für die Reinigung verwenden. Diese Produkte können der Glanz beschädigen.

ACHTUNG

Der Tisch absolut nie ziehen oder heben. Falls der Tisch soll bewegt werden, muss zerlegt werden und sorgfältig in der neue Stelle Positioniert. Die empfindliche teile sollen geschützt werden.

ENTSORGUNG

Nach der Aussonderung ist das Produkt und seine Bestandteile nicht selbständig im Freien zu entsorgen, sondern der städtischen Müllabfuhr zu übergeben.

WARTUNG

Niemals scharfe Werkzeuge aus Metall, spitzen Instrumente oder Schleifmittel für die Reinigung der Oberfläche verwenden. Diese Produkte können die Oberfläche beschädigen. Niemals Chemikalien mit chlorhaltigen Salzsäure, Salzsäure oder Kalk-Produkte für die Reinigung verwenden. Diese Produkte können der Glanz beschädigen.

LEDERPFLEGE

Staub mit einem weichen, trockenen Tuch für die normale Reinigung. Flecken können mit einem feuchten Tuch oder Watte und mit Produkten für die Reinigung zunächst mehr zart wie neutrale Seife oder Reinigungsmilch behandelt werden. Trocknen Sie unmittelbar nach der Behandlung. Vermeiden Sie, um die Oberfläche zu behandeln, reiben, aber tragen Sie eine Schreibunterlage oder Gewebe von den Rändern zur Mitte des Flecks. Scheuernde oder aggressive Produkte wie niemals Lösungsmittel, Fleckentferner, et cetera. Dampf es nie. Verwenden Sie keine Schuhreinigungsprodukte. In jedem Fall jedes Mal, wenn ein neues Produkt für die Reinigung eingesetzt werden, gelten sie in einem "versteckten"-Bereich, um ihre Wirksamkeit zu überprüfen und, wo mehr Schäden sichtbar zu vermeiden.

FR**UTILISATION**

Le produit est destiné pour une utilisation à l'intérieur des habitations.

CONSTRUCTION

Les petites irrégularités sur la base sont dues à une fabrication manuelle.

MANUTENTION

Il ne faut pas absolument utiliser des outils pointus ou des chiffons abrasifs pour éliminer des possibles restes sur la surface du produit, parce qu'ils peuvent endommager la surface même. Ne pas utiliser des détergents contenant du chlore, acide chlorhydrique, acide muriatique ou produits anticalcaire qui peuvent altérer le brillant du produit.

ATTENTION

Ne pas absolument déplacer le produit en le trainant ou en le soulevant par le top, mais démontez-le et positionnez-le autre part, en s'assurant de protéger les parties qui pourraient s'endommager.

ECOULEMENT

Une fois disloqué, le produit ou ses composants ne doivent pas être dispersés dans la nature mais confiés aux décharges publiques.

MANUTENTION

Il ne faut pas absolument utiliser des outils pointus ou des chiffons abrasifs pour éliminer des possibles restes sur la surface du produit, parce qu'ils peuvent endommager la surface même. Ne pas utiliser des détergents contenant du chlore, acide chlorhydrique, acide muriatique ou produits anticalcaire qui peuvent altérer le brillant du produit.

ENTRETIEN PEAU

La poussière avec un chiffon doux et sec pour le nettoyage normal. Les taches peuvent être traitées avec une laine chiffon ou un coton humide et avec des produits pour le nettoyage d'abord plus délicat comme le savon neutre ou lait démaquillant. Sécher immédiatement après le traitement. Évitez de frotter la surface à traiter, mais appliquer un buvard ou de tissus sur les bords vers le centre de la tache. Ne jamais utiliser de produits abrasifs ou agressifs comme les solvants, les détachants, et cetera. Ne jamais cuire à la vapeur. Ne pas utiliser de produits de nettoyage de chaussures. Dans tous les cas, chaque fois qu'un nouveau produit est utilisé pour le nettoyage, appliquer dans une zone «caché» pour tester son efficacité et pour éviter les dommages lorsque plus visibles.

El producto está destinado para su uso dentro del hogar, a los fines por los cuales fue creado.

CONSTRUCCIÓN

Pequeñas irregularidades en la base están causadas por la producción manual.

MANTENIMIENTO

No utilizar en cualquier forma instrumentos de metal afilados o telas abrasivas para eliminar cualquier resto de suciedad en la superficie del producto, ya que pueden dañar la superficie misma. No utilizar en cualquier forma limpiadores a base de cloro o que contienen ácido clorhídrico, ácido muriático o productos anticálceos ya que pueden alterar el brillo del producto.

ATENCIÓN

No muevan absolutamente nunca el producto arrastrándolo o mediante el levantamiento del plano, sino desmontarlo y llevarlo a donde querían, asegurándose de proteger las partes que pueden dañarse.

ELIMINACIÓN DE DESECHOS

Una vez desechado, el producto o sus componentes no se tienen que abandonar en el entorno sino entregar al sistema público de recogida de basuras.

MANTENIMIENTO

No utilizar en cualquier forma instrumentos de metal afilados o telas abrasivas para eliminar cualquier resto de suciedad en la superficie del producto, ya que pueden dañar la superficie misma. No utilizar en cualquier forma limpiadores a base de cloro o que contienen ácido clorhídrico, ácido muriático o productos anticálceos ya que pueden alterar el brillo del producto.

MANUTENCIÓN DE LA PIEL

El polvo con un paño suave y seco para la limpieza normal. Las manchas pueden ser tratadas con un paño o algodón lana mojada y con productos para la limpieza inicialmente más delicada como jabón neutro o leche limpiadora. Seque inmediatamente después del tratamiento. Evitar frotar la superficie a tratar, sino que se aplican una almohadilla de transferencia o tejido de los bordes hacia el centro de la mancha. Nunca utilice productos abrasivos o agresivos como disolventes, quitamanchas, etcétera. Nunca al vapor. No utilice productos de limpieza de zapatos. En todos los casos, cada vez que un nuevo producto se utiliza para la limpieza, aplicar en un área "oculta" para probar su eficacia y evitar daños en los que más visibles.

ИСПОЛЬЗОВАНИЕ

Изделие предназначено для использования внутри помещения.

РЕАЛИЗАЦИЯ

Небольшие неровности на основе связаны с обработкой изделия вручную.

ВНИМАНИЕ

При перемещении изделия, никогда не перетаскивайте и не поднимайте его, взяв за верх, для начала разберите его и переставьте в нужное место, позаботившись о защите частей, которые могут быть повреждены.

УТИЛИЗАЦИЯ

После утилизации, продукт и его компоненты не должны разолгаться в окружающей среде, а должны быть переданы в специализированные места утилизации.

УХОД

Не используйте острые металлические инструменты или абразивные губки для удаления грязи, так как они могут повредить поверхности. Ни в коем случае не используйте моющие средства, содержащие хлор, соляную кислоту или средства от известкового налета, поскольку они могут повлиять на блеск предмета.

УХОД ЗА КОЖЕЙ

Для обычной чистки протрите пыль мягкой сухой тканью. Пятна можно удалить, обработав их влажной тканью или ватой и деликатными чистящими средствами, такими как мягкое мыло или очищающее молочко. Высушите сразу после обработки. Не трите обрабатываемую поверхность, а промокните пятна от краев к центру. Никогда не используйте абразивные или агрессивные средства, такие как растворители, пятновыводители и т. Д. Никогда не используйте пар. Не используйте чистящие средства для обуви.

В любом случае, каждый раз, когда вы используете новое чистящее средство, наносите его на «скрытую» область, чтобы проверить его эффективность и не повредить более открытые участки.

使用:

此产品仅限于室内使用,也只能按其用途使用。

注:

底座上的小的不规则处是手工加工产生的

警告:

请勿通过拖拽或是抬起桌面来移动产品,应将其放在要放的位置重新组装,以避免损坏产品部件。

处理方法:

如果家具不能使用或是不能修复,不要把产品及其部件散步在外面,应将其交由公共处置系统。保养

不建议

使用锋利的金属工具或磨料织物去除表面上的污垢,因为它们可能会损害产品。请勿使用含有氯林,盐酸,氢氯酸的洗涤剂或浓缩洗涤剂清理产品,因为它们会破坏产品表面的光泽。

皮革护理

日常清洁可以用柔软干燥的布擦拭。污点可以用湿布或棉羊毛来处理,也可以用像中性肥皂或清洁膏一样的温和清洁剂。清洁后需立即干燥。避免摩擦表面,用一片吸油纸或者纸巾从边缘向中心擦拭,请勿使用刺激性清洁产品,比如溶解剂,去污剂等等。

请勿使用蒸汽及鞋履清洁产品。对新产品进行第一次清洁时,先在较“隐蔽”的区域进行测试查看清洁效果,避免在明显的地方造成损害。

**cattelan
italia**

CATTELAN ITALIA SPA
Via Pilastri, 19
36010 Carré (VI), Italy
Ph. +39 0445 318711
info@cattelanitalia.com
www.cattelanitalia.com

